

MAXIM

MAX3901 Evaluation Kit

General Description

The MAX3901 evaluation kit (EV-kit) provides electrical evaluation of the MAX3901 automotive fiber optic receiver. The EV-kit also includes two optical evaluation sections. The first allows for optical evaluation using a separate photodiode. The second section contains the footprint for an automotive optical assembly.

Component List

DESIGNATION	QTY	DESCRIPTION
C1	1	0.01 μ F \pm 10% Ceramic Capacitor (0402)
C2	1	0.022 μ F \pm 10% Ceramic Capacitor (0402)
C7, C11, C12, C36	4	Open
C10, C13, C14, C16 – C21, C24, C27, C39 – C41	14	0.1 μ F \pm 10% Ceramic Capacitors (0402)
C15, C25, C26	3	10 μ F \pm 5% Tantalum Capacitor (B Case)
C28	1	2pF \pm 10% Ceramic Capacitor (0402)
J1, J4, J8, J17, J18	5	SMA connectors (edge-mount, tab contact)
J6, J10 – J13, TP3, TP4, TP7 – TP9, TP13, TP14	12	Test Points
JU4, JU5	3	2-pin headers, 0.1in centers
L2	1	1 μ H \pm 5% inductor (1008CS)
Q1 – Q6	6	NPN Transistors Philips PFS540
R1, R3, R23	3	1.0k Ω \pm 1% resistor (0603)
R2, R16, R28	3	5.11k Ω \pm 1% resistor (0603)
R4, R5	2	2.37k Ω \pm 1% resistors (0603)
R6, R13, R18, R38	4	49.9 Ω \pm 1% resistor (0603)
R7, R9, R24 – R27, R35	7	0 Ω \pm 1% resistor (0603)
R8, R10, R36	3	49.9k Ω \pm 1% resistor (0603)
R11	1	511 Ω \pm 1% resistor (0603)
R12, R14, R17, R19, R21, R39	6	499 Ω \pm 1% resistor (0603)
R15, R20, R40	3	10 Ω \pm 1% resistor (0603)
R22	1	10k Ω \pm 1% resistor (0603)
R29	1	3.01k Ω \pm 1% resistor (0603)
R30	1	1.5k Ω \pm 1% resistor (0603)
U1, U2	2	MAX3901 die in QFN24
U3	1	Optical Device (Not Supplied)
None	2	Shunts
None	1	MAX3901EV board

Features

- ◆ Easy +5.0V Power Supply Operation
- ◆ Fully Assembled and Tested
- ◆ Optical Evaluation Possible

Ordering Information

PART	TEMP. RANGE	IC PACKAGE
MAX3901EVKIT	-40°C to +125°C	24QFN

Component Suppliers

SUPPLIER	PHONE	FAX
AVX	843-444-2863	843-626-3123
Coilcraft	847-639-6400	847-639-1469
Digi-Key	218-681-6674	218-681-3380
EF Johnson	402-474-4800	402-474-4858
Murata	415-964-6321	415-964-8165

Note: Please indicate that you are using the MAX3901 when ordering from these suppliers.

Quick Start

Electrical Evaluation

- 1) Install a shunt across JU4. Remove shunt from JU5.
- 2) Connect a +5.0V power supply to J6 and J11. Connect ground to J10 and J12. Connect a -15V power supply to J13.
- 3) Connect a DC current source to J18 and adjust the input current to 220 μ A.
- 4) Connect a data signal to J1 (IN) with a 2V_{P-P} amplitude. This will create a 444 μ A_{P-P} input current.
- 5) The output can be monitored either with a high impedance probe at TP4, or by connecting a high-speed 50 Ω oscilloscope to J8.

Optical Evaluation

The MAX3901 EV kit contains two optical evaluation sections. One requires a separate photodiode, the other requires an optical assembly. Refer to Figure 1.

- 8) The output can be monitored either with a high impedance probe at TP14 or TP9, or by connecting a high-speed 50 Ω oscilloscope to J17 or J4.
- 9) Connect a voltmeter to TP13 or TP9 (STATUS). The output will indicate if the optical connection is successful.

MAX3901 Evaluation Kit

Evaluate: MAX3901

Adjustment and Control Description (see Quick Start first)

COMPONENT	NAME	FUNCTION
JU4	-	Installing a shunt across JU4 emulates photocurrent at the FILTER pin, which allows MAX3901 to enter the operational mode (STATUS = LOW). Removing shunts from JU4 enters the standby mode (STATUS=HIGH).
JU5	-	Used for bypassing the supply filtering if needed.

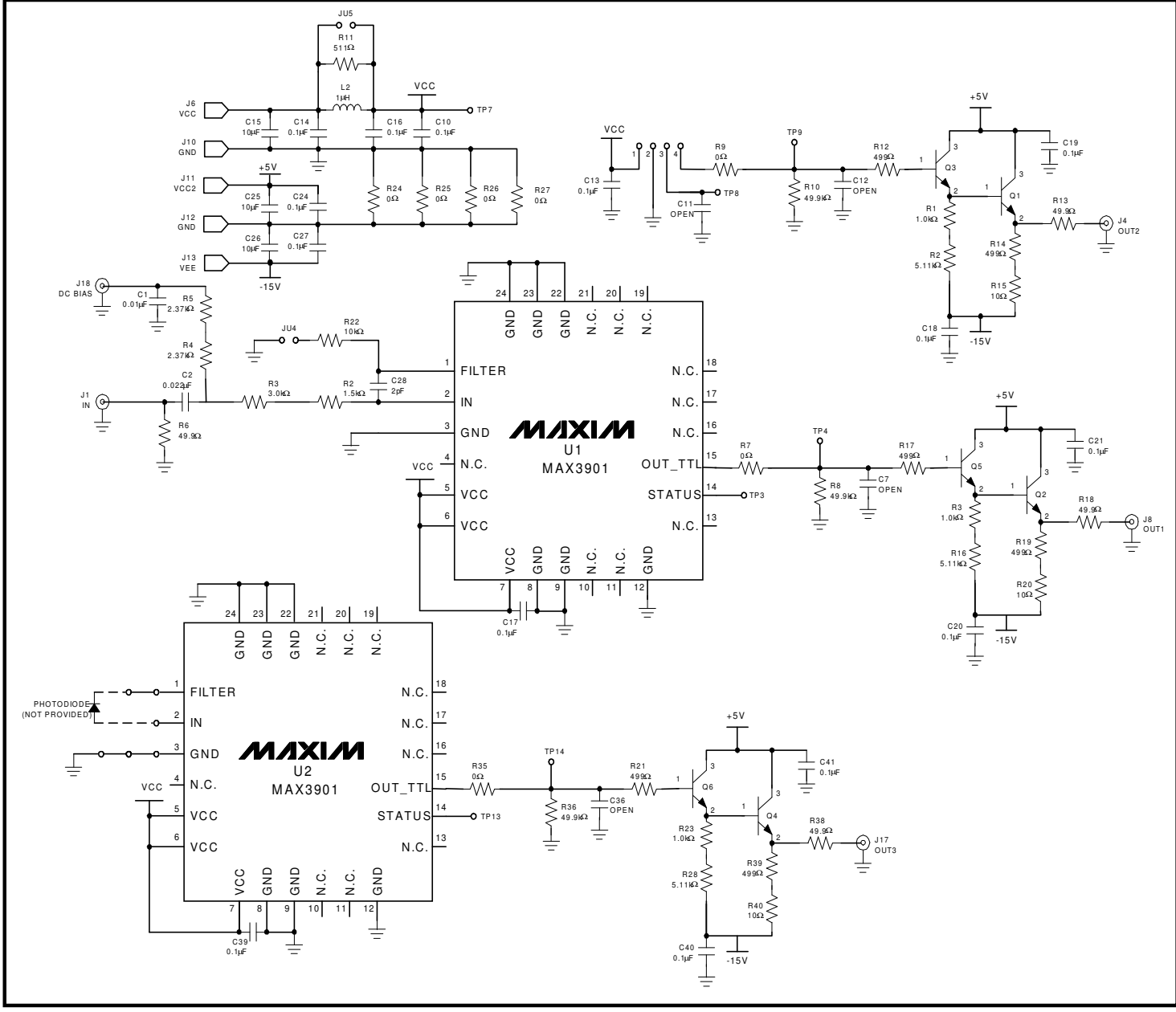

Figure 1. MAX3901 EV Kit Schematic Diagram

MAX3901 Evaluation Kit

Evaluates: MAX3901

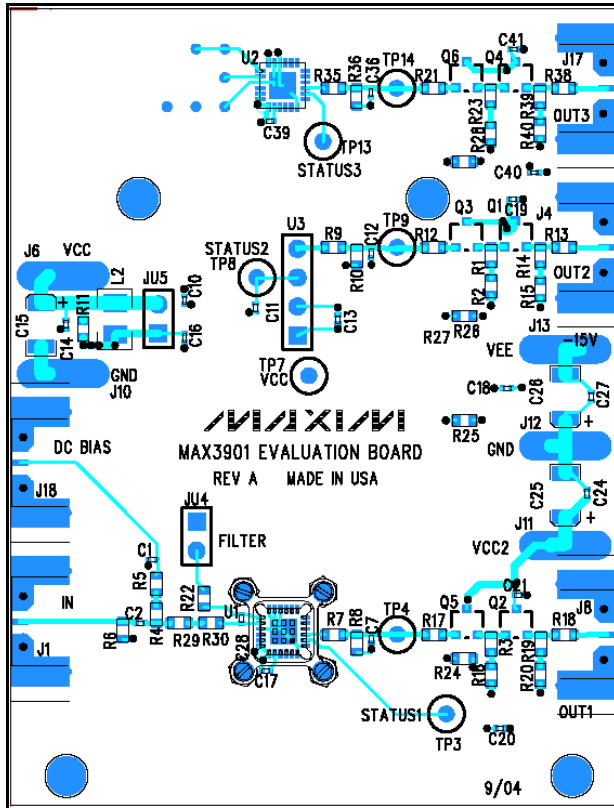

Figure 2. MAX3901 EV Kit Component Placement Guide - Component Side

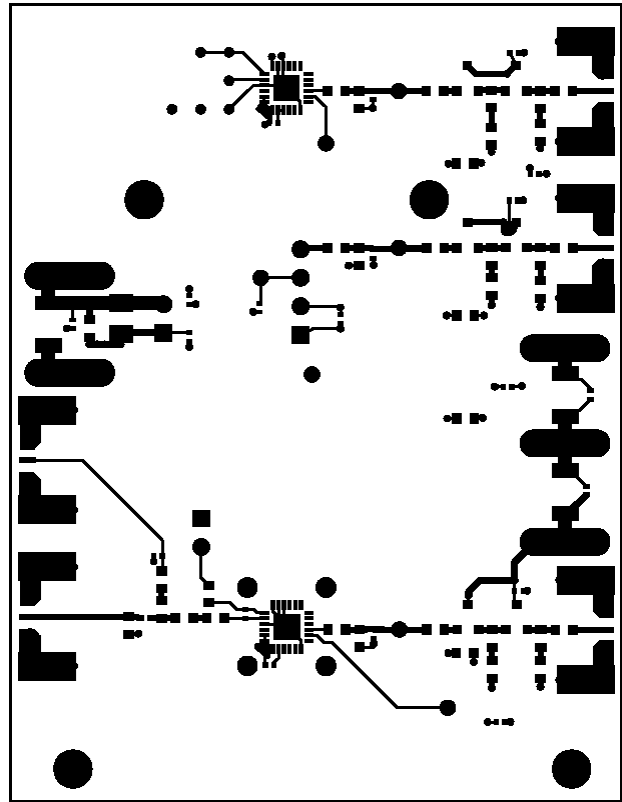

Figure 3. MAX3901 EV Kit PC Board Layout - Solder Side

MAX3901 Evaluation Kit

Evaluate: MAX3901

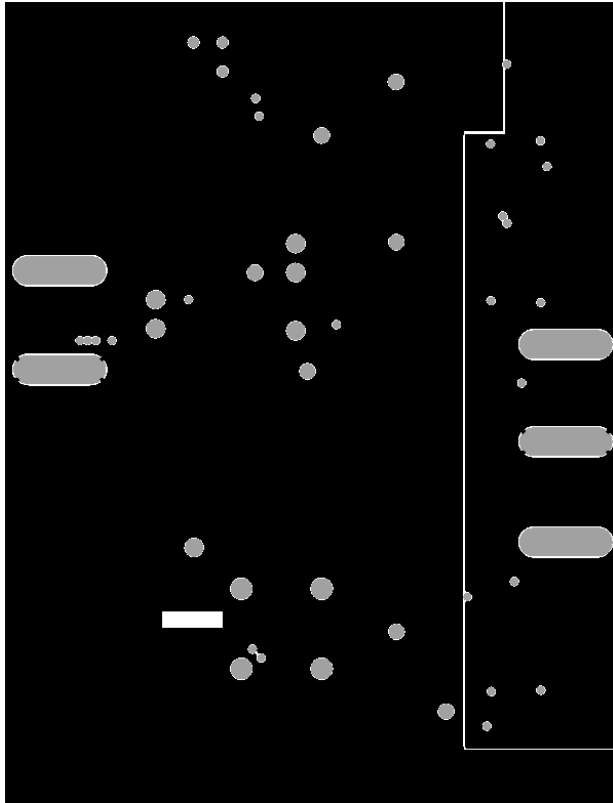

Figure 4. MAX3901 EV Kit PC Board Layout - Ground Plane

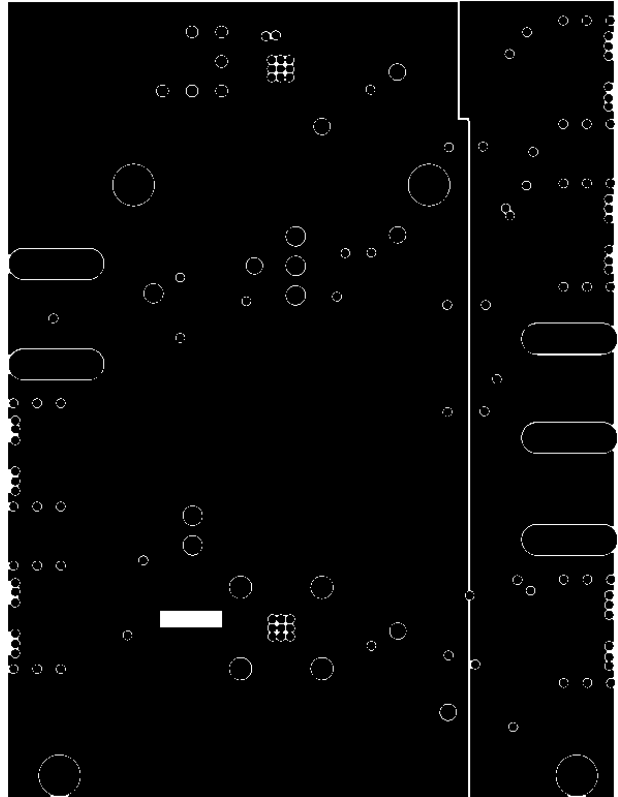

Figure 5. MAX3901 EV Kit PC Board Layout - Power Plane

Maxim cannot assume responsibility for use of any circuitry other than circuitry entirely embodied in a Maxim product. No circuit patent licenses are implied. Maxim reserves the right to change the circuitry and specifications without notice at any time.

4 _____ Maxim Integrated Products, 120 San Gabriel Drive, Sunnyvale, CA 94086 408-737-7600